

**PLAN VIEW**

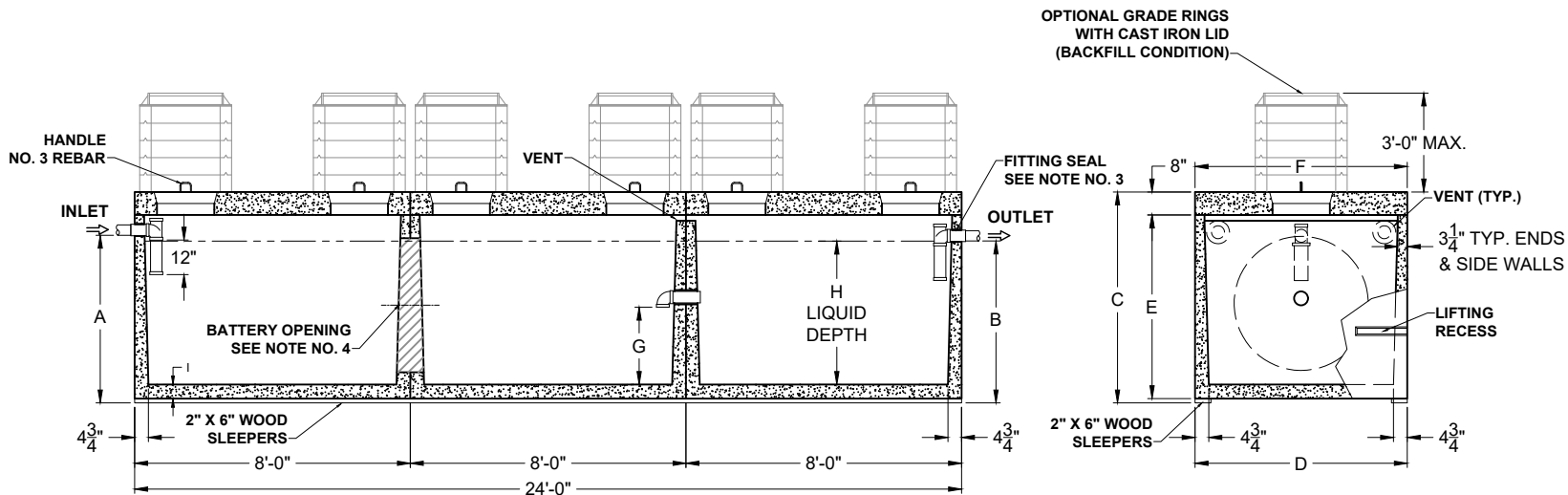

**SECTION THRU "A-A"**

**SECTION THRU "B-B"**

**H-20 TRAFFIC RATED  
"HEAVY DUTY"**

ALL DIMENSIONS ARE IN INCHES & WEIGHTS IN LBS - (RISER WT. NOT INCLUDED)										EXCAVATION SPECIFICATIONS				
MODEL	A	B	C	D	E	F	G	H	I	WEIGHT	LENGTH	WIDTH	BELOW INLET	TANK HEIGHT
PC S-3-3750-HD	59	57	74	74	64	74	29 1/4	50 1/2	4 1/2	41,625	27'-0"	9'-2"	4'-11"	6'-2"
PC S-3-4500-HD	62 1/2	60 1/2	77 1/2	85	67 1/2	85	30 3/4	53 1/2	5	48,660	27'-0"	10'-1"	5'-2 1/2"	6'-5 1/2"

**PRODUCT NAME:  
HD SEPTIC TANK**

**DESCRIPTION:  
3750 THRU 4500 GALLONS  
H-20 TRAFFIC RATED**

**DESIGN SPECIFICATIONS  
DESIGN LOAD: H-20 TRAFFIC RATED**

WITH DRY SOIL CONDITIONS (WATER LEVEL BELOW TANK). SUITABLE SUB-BASE BEDDED WITH GRANULAR MATERIAL SHALL BE PREPARED TO HANDLE ANTICIPATED LOADS. FOR COMPLETE DESIGN AND PRODUCT INFORMATION, PLEASE CONTACT PRO-CAST PRODUCTS.

PRO-CAST PRODUCTS RESERVES THE RIGHT TO MAKE CHANGES TO PRODUCT DESIGN AND/OR DIMENSIONS WITHOUT NOTICE. PLEASE CONTACT PRO-CAST PRODUCTS WHENEVER NECESSARY FOR CONFIRMATION OR ADVICE ON PRODUCT DESIGN.

**NOTES:**

1. NOT USED
2. REFER TO SPECIFICATION SHEET NOS. S-251 & S-252
3. REFER TO SPECIFICATION SHEET NO. S-201
4. REFER TO SPECIFICATION SHEET NO. S-250

**SCALE: DO NOT SCALE**

**DRAWN BY: TPC 12.20.2024**

**REVISED BY:**

**CHECKED BY:**

**DRAWING NO.**

**HD-S-004**